

FOUR-MANIFOLDS AS 4-FOLD BRANCHED COVERS OF S^4

R. PIERGALLINI

*Dipartimento di Matematica
Università di Perugia*

ABSTRACT

Covering moves introduced in [6] are used in order to affirmatively answer the question posed by Montesinos in [3]. As an application, we prove that every closed orientable PL 4-manifold is a 4-fold simple covering of S^4 branched over a transversally immersed PL surface.

Introduction

In [3] Montesinos asks if the moves C^\pm and N^\pm described in figure 1, suffice in order to relate any two simple 4-fold coverings $p_1, p_2 : \#_n(S^1 \times S^2) \rightarrow S^3$ branched over a link and coming from 3-fold coverings by addition of a trivial sheet.

He also observes that, if this is the case, then every closed oriented PL 4-manifold is a simple 4-fold covering of S^4 branched over an immersed PL surface with only cusp and node singularities, that is singularities which are topologically equivalent to cusps and nodes of algebraic curves in the complex plane.

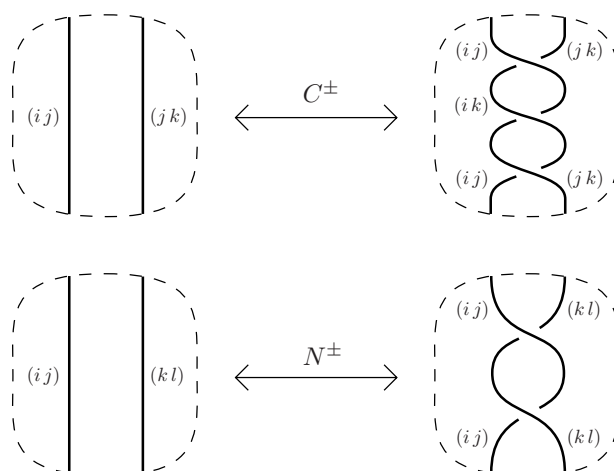

Figure 1.

In section 1 of this paper (Theorem A), we affirmatively answer the Montesinos's question, by proving that moves C^\pm and N^\pm allows us to relate any two coverings as above, which represent the same 3-manifold (not necessarily $\#_n(S^1 \times S^2)$).

In section 2 (Theorem B), we improve the above mentioned application to 4-manifolds, by showing that in fact all the cusps of the branch surface can be eliminated, in such a way that we get a transversally immersed surface, that is a surface which is locally flat except for a finite number of transversal double points.

This is the main result of our work, since it is, as far as we know, the first general result in representing all 4-manifolds as branched covering spaces of S^4 , with a bounded (in fact the minimum possible, cf. [1]) number of sheets.

In section 3 (Problem C) we briefly discuss the possibility of getting a locally flat branch surface.

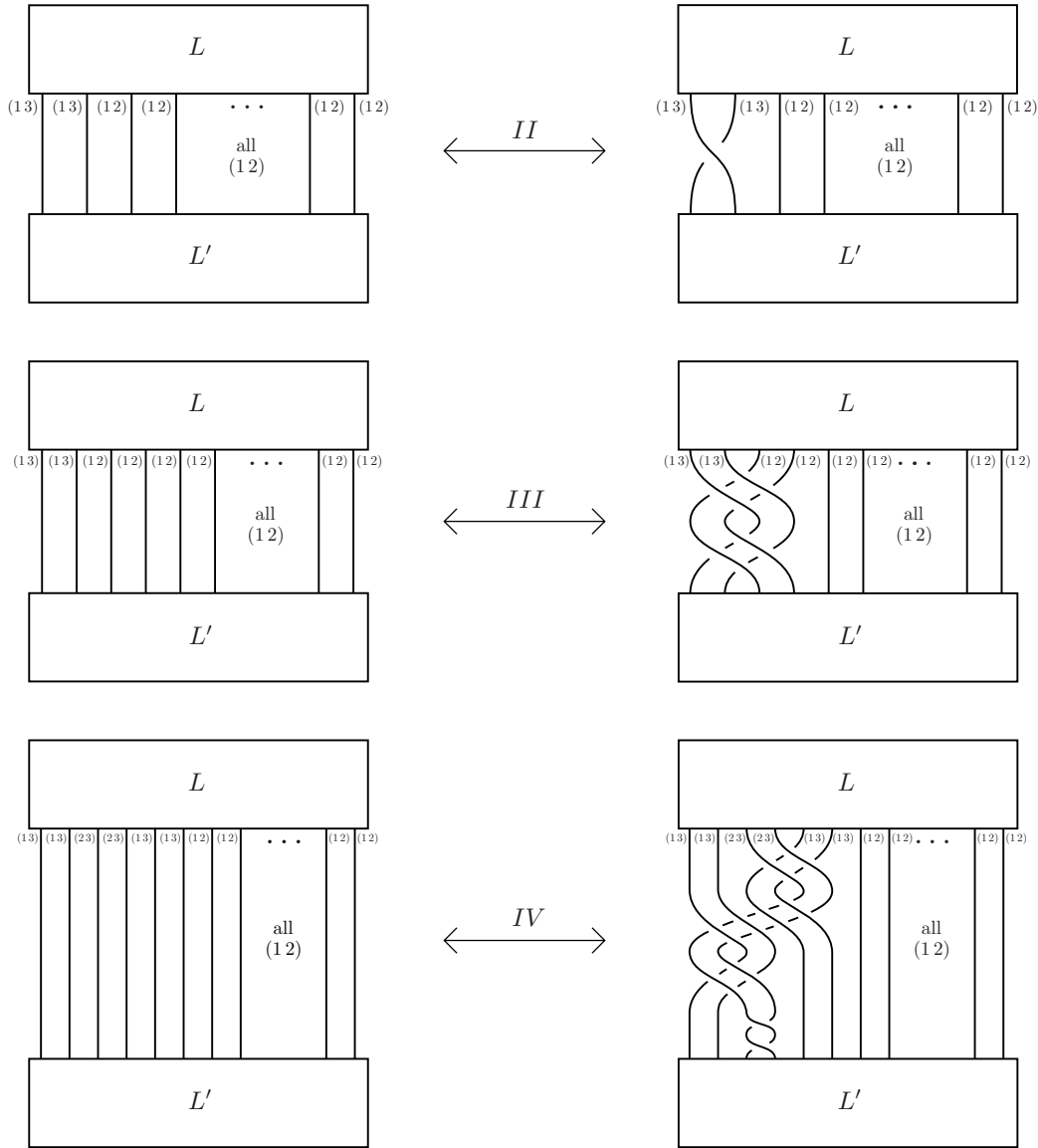

Figure 2.

1. Equivalence of simple branched coverings of S^3

In [6] it is proved that any two 3-fold simple coverings of S^3 branched over a link, representing the same 3-manifold, can be related by a finite sequence of moves C^\pm and moves as described in figure 2 (where transpositions give, as well as in figure 1, the monodromy of the meridians around the corresponding bridges, of course up to conjugation in S_3 , and L, L' are two arbitrary links).

In this section, we use such moves in order to prove the following theorem, which provides an affirmative answer to the Montesinos's question mentioned in the introduction.

Theorem A. *Any two simple 4-fold coverings of S^3 branched over a link and coming from 3-fold coverings by addition of a trivial sheet, which represent the same 3-manifold, can be related by a finite sequence of moves C^\pm and N^\pm .*

Proof. We need only to prove that, in presence of a fourth trivial sheet, that is of an unknotted and unlinked component of the branch link whose meridian has monodromy

(34), moves $II-IV$ can be generated by moves C^\pm and N^\pm . That is done in the figures 3, 4 and 5.

We conclude this section with the following question, that is naturally suggested by the theorem above.

Question. Are the moves C^\pm and N^\pm (perhaps together with addition/deletion of trivial sheets) sufficient in order to relate any two simple 4-fold (n -fold) branched (over a link) coverings of S^3 representing the same 3-manifold?

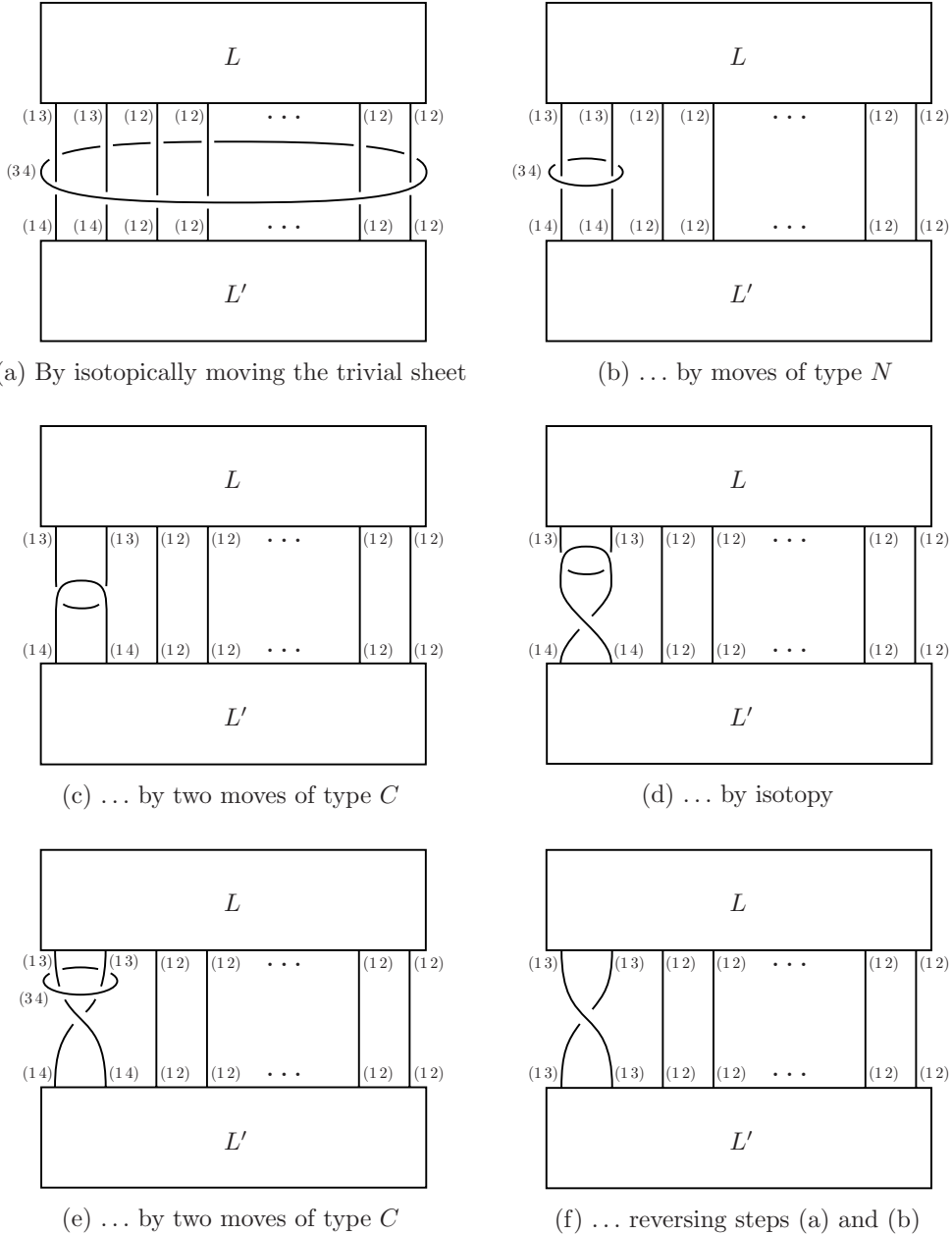

Figure 3.

2. Four-manifolds as 4-fold branched covers of S^4

As observed by Montesinos in [3], an immediate consequence of theorem 6 of [4] and our theorem A is that every closed oriented PL 4-manifold is a simple 4-fold covering of

S^4 branched over an immersed PL surface with only node and cusp singularities. This section is completely dedicated to prove the following improvement of such fact.

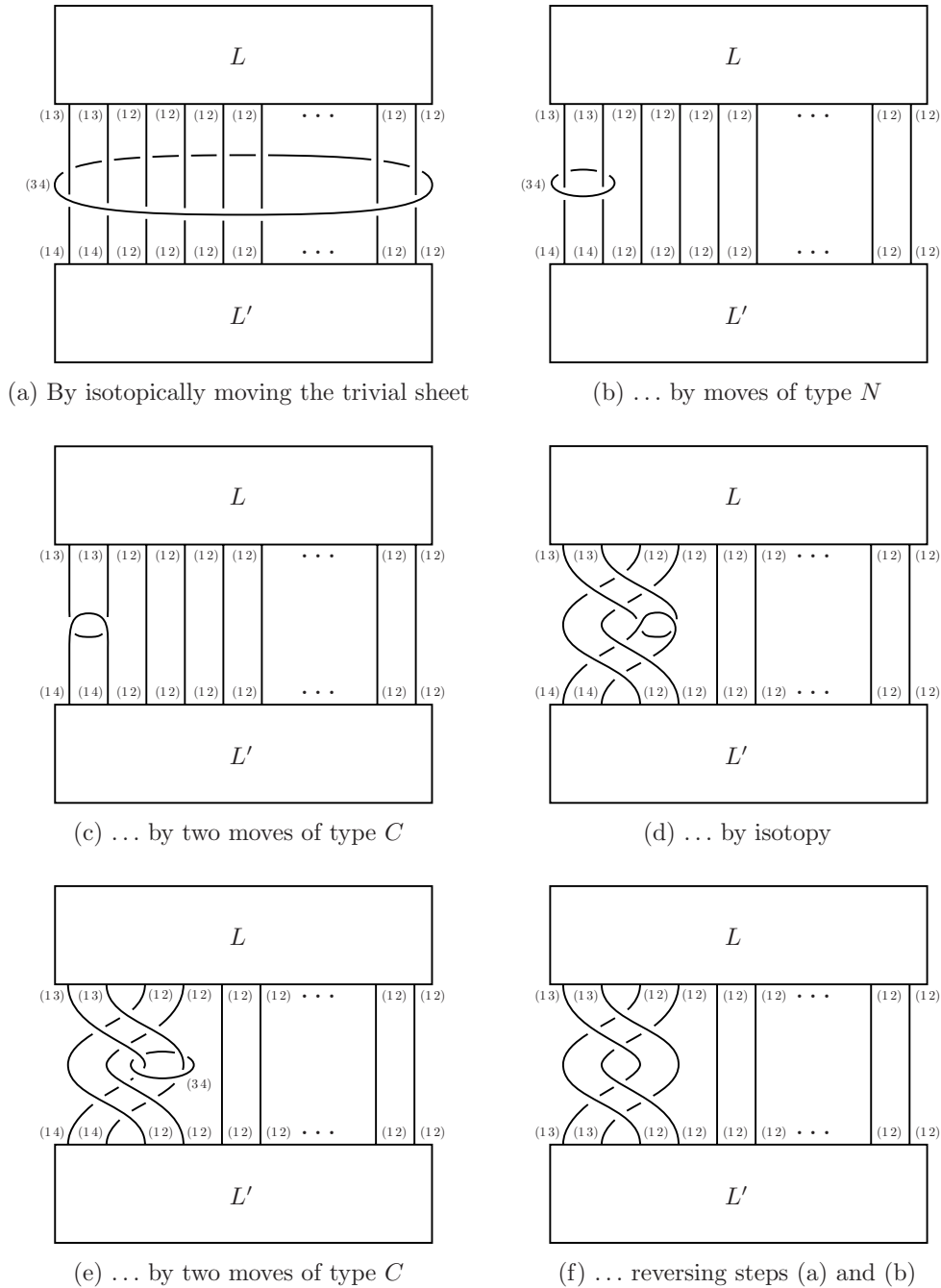
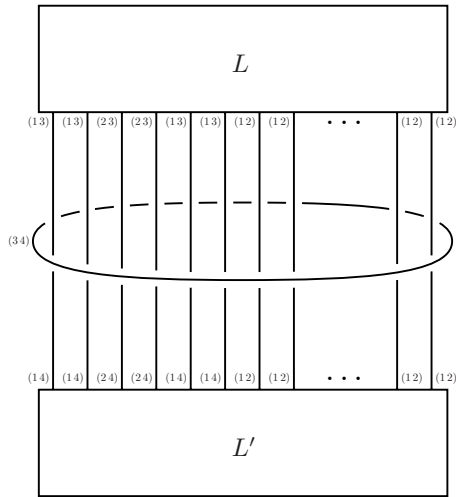

Figure 4.

Theorem B. *Every closed oriented PL 4-manifold is a simple 4-fold covering of S^4 branched over a transversally immersed PL surface.*

Proof. Let M be a closed oriented PL 4-manifold. Following Montesinos (cf. [3]), we start by considering a covering $p : M \rightarrow S^4$ branched over an immersed PL surface F with only node and cusp singularities. For sake of completeness, we include a sketch of construction of such a covering.



(a) By isotopically moving the trivial sheet

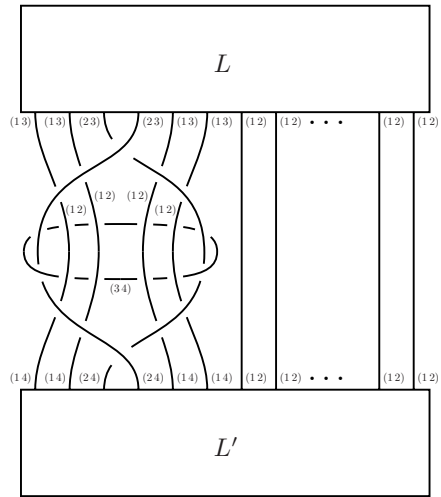

(b) ... by moves of type N and isotopy

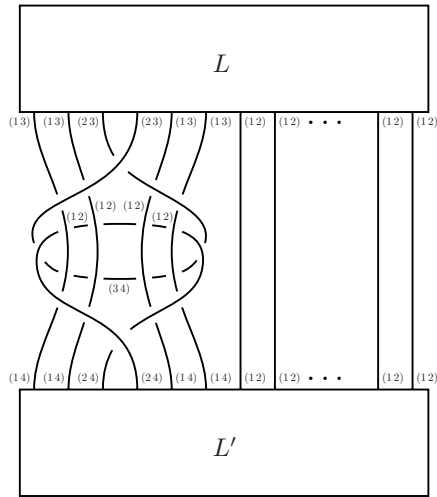

(c) ... by two moves of type C

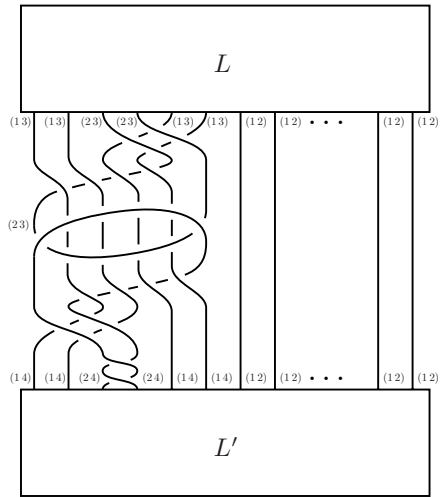

(d) ... by isotopy

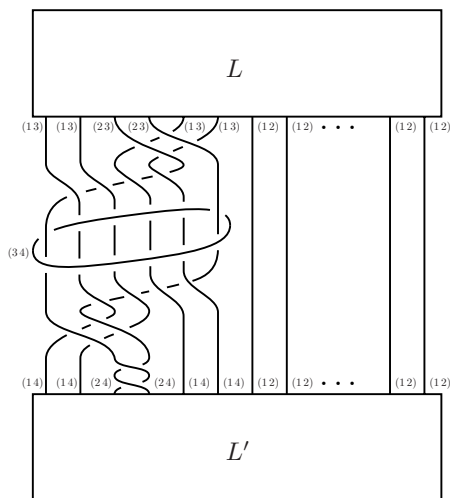

(e) ... by two moves of type C

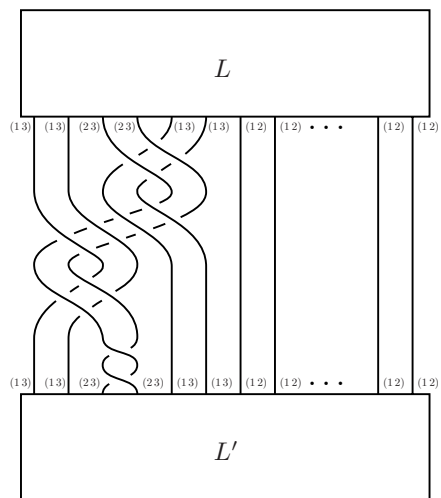

(f) ... reversing steps (a) and (b)

Figure 5.

By using a handlebody decomposition of M , we can write $M = M_0 \cup M_1$ with $M_1 \cong \#_n(S^1 \times B^3)$. Moreover, by [4], there exist two simple 3-fold coverings $\pi : M_i \rightarrow B^4$ branched over PL regularly imbedded surfaces $F_i \subset B^4$. Let \tilde{p}_i denote the covering obtained by adding a trivial sheet to p_i and r_i denote the restriction of \tilde{p}_i to the boundary.

Then, we can apply theorem A in order to get a finite sequence of moves C^\pm and N^\pm connecting r_0 to r_1 . Now it is quite easy (cf. [3]) to construct a simple 4-fold covering $r : \#_n(S^1 \times S^2) \times [0, 1] \rightarrow S^3 \times [0, 1]$ branched over a PL immersed surface with a cusp for every move C^\pm and a node for every move N^\pm , whose restriction to the boundary coincides with $r_0 \cup r_1$.

Finally, by gluing the coverings \tilde{p}_0 , r and \tilde{p}_1 together, along their boundaries, we obtain a branched covering $p : M \rightarrow S^4$ (whose covering space is M because of [5]), as required.

We can assume that $F - \{\text{singular points}\}$ is connected. In fact if F_1 and F_2 were distinct components of it, then we could connect them by a simple arc, and insert two cusps inside a small regular neighborhood of such an arc, as sketched in figure 6, in order to get only one component.

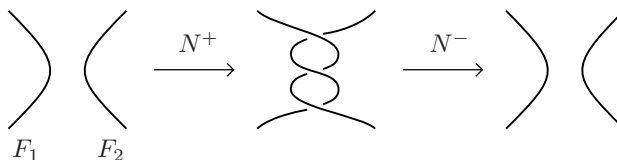

Figure 6.

Now we pass to show how to eliminate all the cusps of the branch surface F of the covering p obtained above.

First of all, we note that the restriction of the covering p over a neighborhood of a cusp of F looks like the cone of an irregular 3-fold covering of S^3 onto itself branched over a trefoil knot, plus a disjoint trivial fourth sheet. So we can say that such a cusp is a left- or right-handed one, according to the corresponding trefoil knot in S^3 . Then, we can associate to p the number

$$\Gamma(p) = (\# \text{ of left-handed cusps}) - (\# \text{ of right-handed cusps}).$$

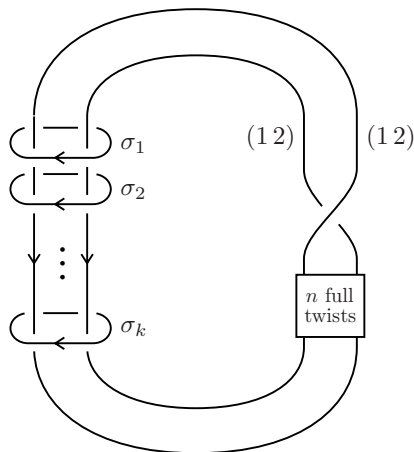

Figure 7.

We claim that $\Gamma(p) \equiv 0 \pmod 3$. By [2], this is true for any 3-fold covering p' of S^4 branched over an orientable surface with only cusp singularities. Hence, it suffices to show that there exists such a covering p' , with $\Gamma(p) \equiv \Gamma(p') \pmod 3$.

We start by observing that the moves $II-IV$ of figure 2 can be realized by means of cobordisms (non-oriented for move II) respecting the monodromy, without using the fourth sheet and the moves N^\pm . In fact, by replacing 4 by 3 in figure 3 (c) and (d), we get a link which is obviously cobordant to both the braids of move II . The same is true for figure 4 (c) and (d) and move III . For move IV , we cannot use figure 5, but it is clear that the cobordism can be constructed in a similar way.

Then, by using cobordism, we get a 3-fold covering p'' of S^4 branched over a surface F'' with only cusp singularities, such that $\Gamma(p) = \Gamma(p'')$.

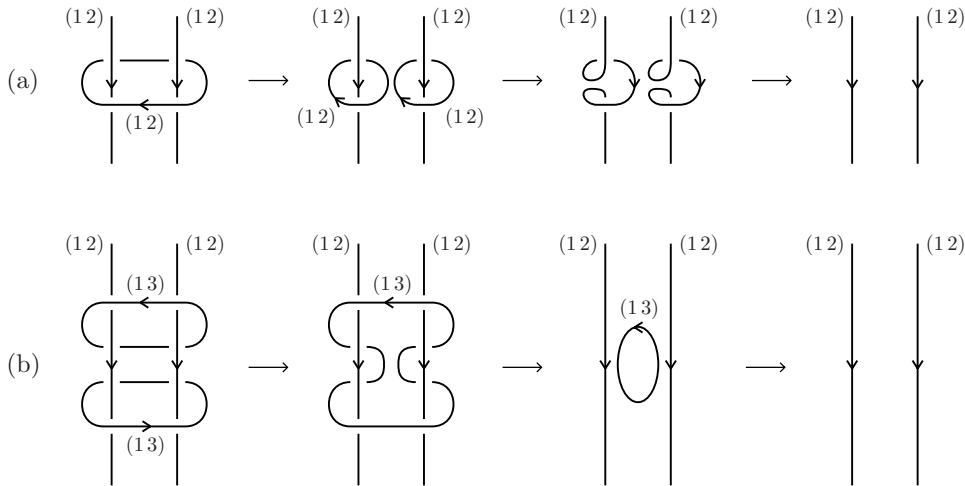

Figure 8.

If F'' is orientable we put $p' = p''$. Otherwise, let $\lambda \subset F''$ be an orientation reversing simple loop such that $F'' - \lambda$ is orientable, D be a locally flat PL disk in S^4 , such that $\text{Bd } D = \lambda$ and $\text{Int } D$ is transversal with respect to F'' , and B_D be a small regular neighborhood of D in S^4 . By looking at the boundary of B_D , we have (up to conjugation in S^3) the link represented in the following figure 7 (where $k = \#(\text{Int } D \cap F'')$).

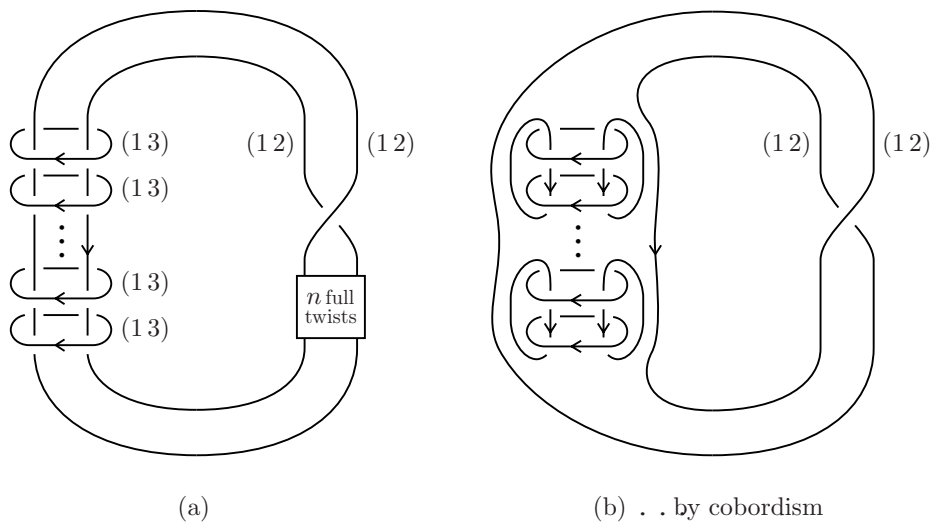

Figure 9.

Now, in order to get a covering p' as required, it is enough to show that such link bounds an immersed oriented surface in B^4 with a number of cusps (counted with sign) which is a multiple of 3.

Since the loops with $\sigma_i = (12)$ can be eliminated as shown in figure 8 (a), we can easily assume (up to conjugation in S^3) that $\sigma_i = (13)$ for every $i = 1, \dots, k$. Then, we can also assume that all the small loops in figure 7 are oriented in same way (otherwise we could simplify the link as shown in figure 8 (b)).

In figure 9 it is shown how to separate the component of the link with monodromy (12) , in such a way that we are left (up to oriented cobordism) with $k/2$ copies of the link of figure 10 (a). Finally, figure 10 shows how to modify this last link into 3 right-handed trefoil knots, which bound 3 right-handed cusps.

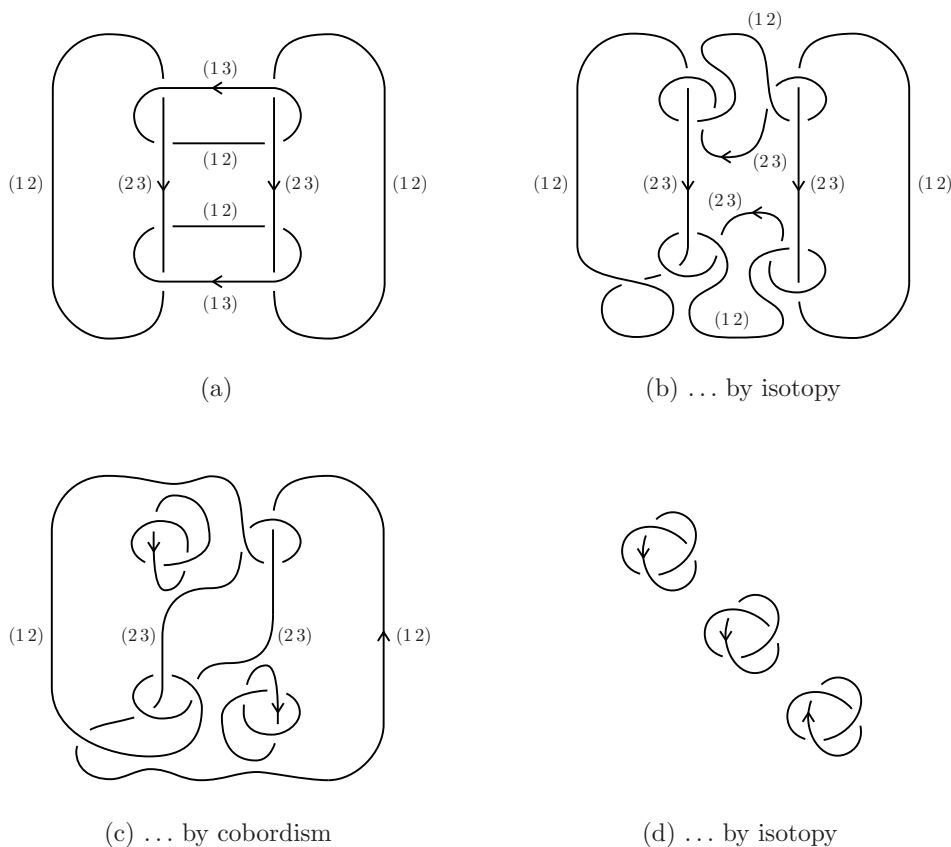

Figure 10.

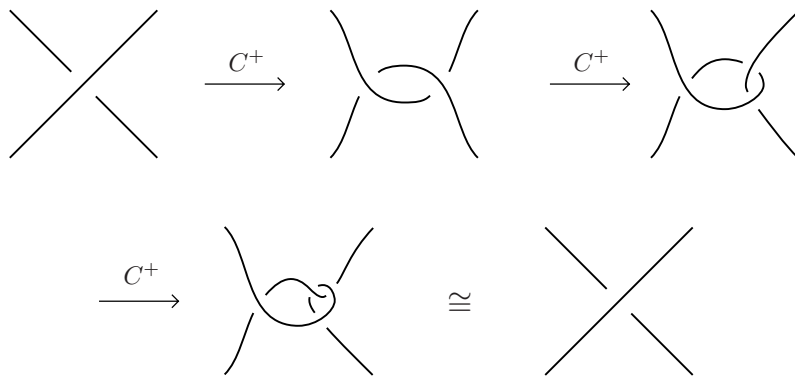

Figure 11.

Figure 11 shows how three left-handed cusps can be added in the branch surface F of the covering p , by means of a sequence of C^+ moves; of course, three right-handed cusps can be added by using C^- moves.

Hence, we can assume that $\Gamma(p) = 0$. Then, in order to conclude the proof of the theorem, it is enough to show how to eliminate a pair of one left- and one right-handed cusp.

We will use the auxiliary move described in figure 12. Such a move, which is the composition of two moves of type C , can also be realized without introducing any cusp. In fact, the intersection of the branch surface F with the boundary of the 4-cell $B \cong E \times [0, 1]$, where E is a small 3-cell inside which the move takes place, is the trivial link shown in figure 13, so that we can substitute $F \cap B$ with two disjoint trivial disks.

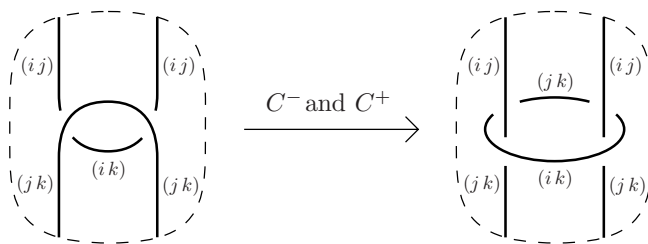

Figure 12.

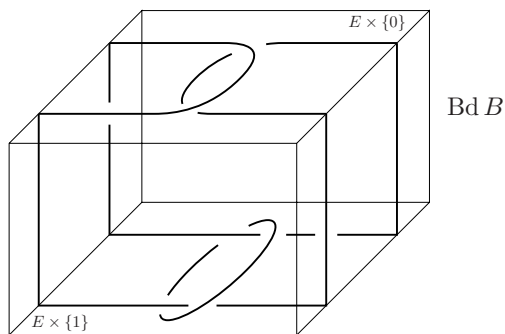

Figure 13.

Now, let γ_1 and γ_2 be a left- and a right-handed cusp arbitrarily chosen in F . Since we have supposed that F is connected, there exists a simple arc $\alpha \subset F$ between γ_1 and γ_2 avoiding all other singularities of F . Let B_α be a small regular neighborhood of α in S^4 , whose boundary meets F transversally.

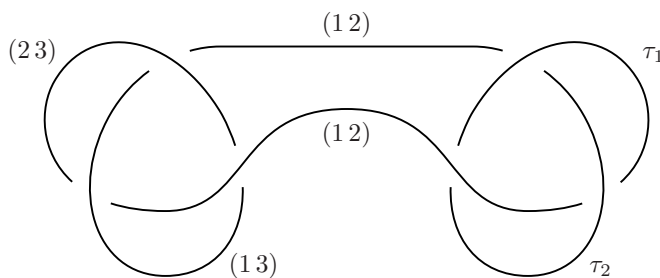

Figure 14.

Then, $F \cap \text{Bd } B_\alpha$ is the square knot $K = K_1 \# K_2$, where K_i is the trefoil knot corresponding to the cusp γ_i . Of course, we can assume, up to conjugation, that the monodromy around γ_1 is as in figure 14.

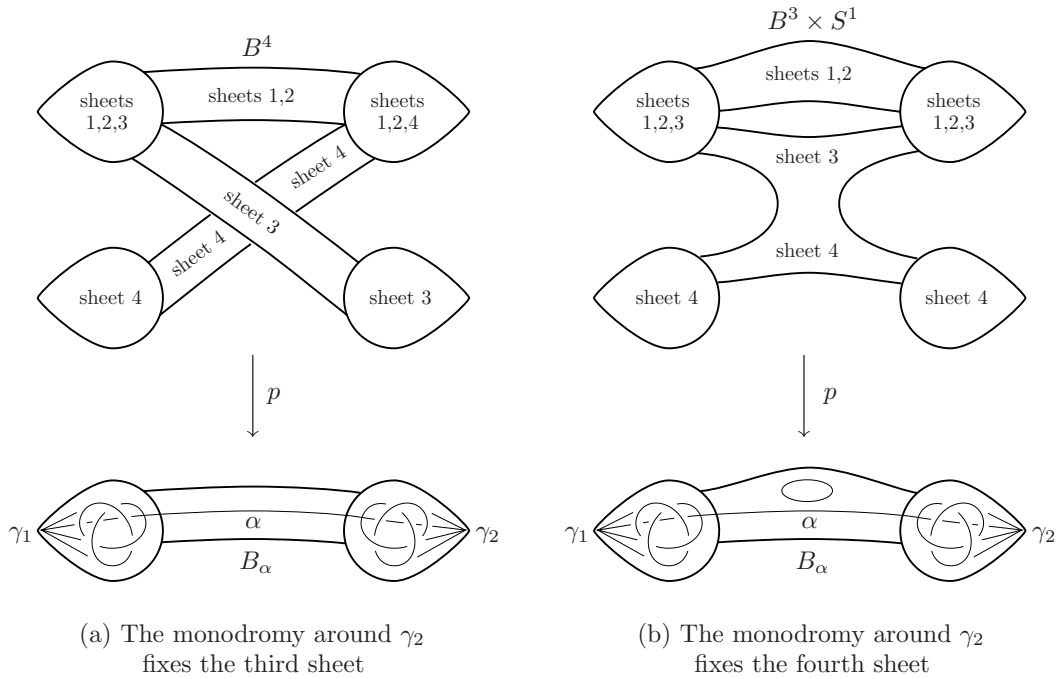

Figure 15.

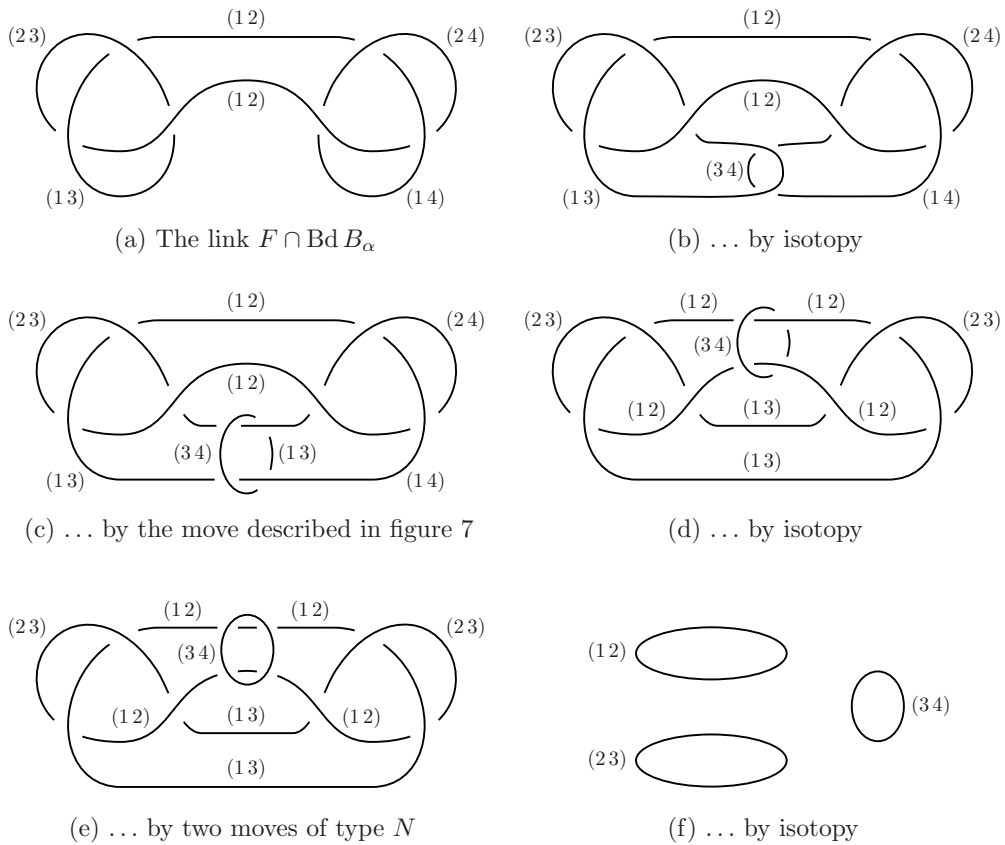

Figure 16.

We also assume, for the moment, that the monodromy around γ_2 fixes the third sheet, so that B_α is covered by a 4-cell (cf. figure 15 (a)).

At this point, we have only two possibilities: $\tau_1 = (14)$ and $\tau_2 = (24)$, or $\tau_1 = (24)$ and $\tau_2 = (14)$. In the first case, we can substitute $F \cap B_\alpha$ with the surface described by the sequence of links in figure 16 (starting from the boundary of B_α and obviously ending with trivial disks), which do not contain any cusp. The same technique can be also used in the second case, except for the fact that now the arc corresponding to τ_2 play the role of the arc corresponding to τ_1 . In both cases, the manifold covering B_α after the substitution is still a 4-cell, then the global covering manifold is still M .

Finally, we see what happens when the monodromy around γ_2 fixes the fourth sheet, that is $\tau_1 = (13)$ and $\tau_2 = (23)$, or $\tau_1 = (23)$ and $\tau_2 = (13)$. As before, we limit ourselves to deal with the first choice.

In this case, we move a finger of F with monodromy (34) inside B_α , in such a way that looking at $\text{Bd } B_\alpha$, we have the situation shown in part (a) of figure 17. Then, the manifold covering B_α is homeomorphic to $B^3 \times S^1$ (cf. figure 15 (b)).

Figure 17 shows how to start the description of the surface that we substitute to $F \cap B_\alpha$, in order to eliminate the cusps γ_1 and γ_2 , the rest of such a surface is obtained adding a trivial loop with monodromy (34) to each step of figure 16. As above, the manifold covering B_α after the substitution is still homeomorphic to $B^3 \times S^1$, then the global covering manifold is still M (by [5]).

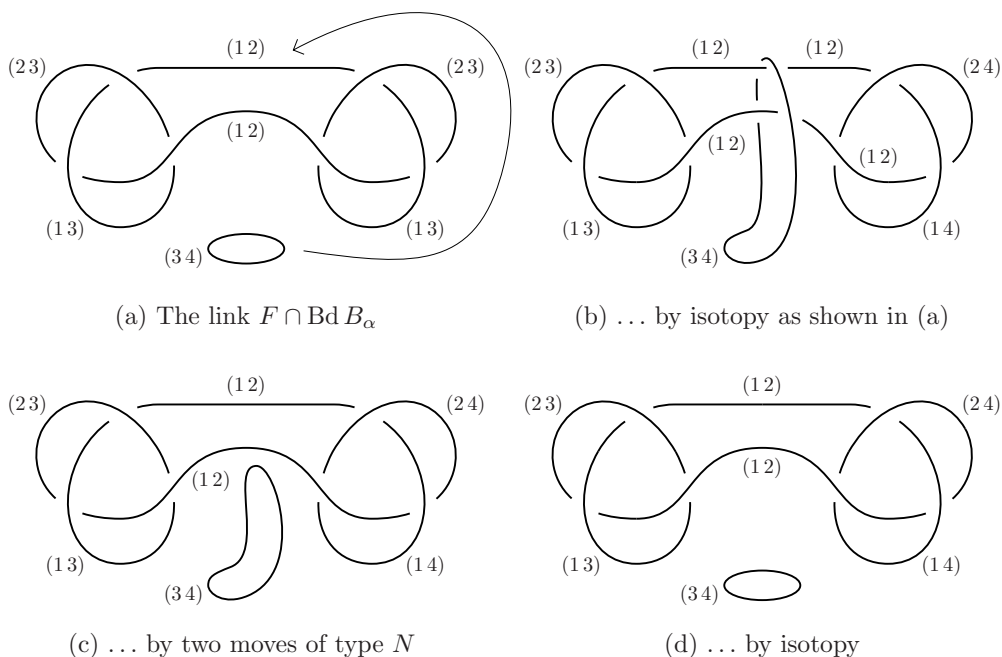

Figure 17.

We conclude the proof by observing that, after the elimination of the two cusps γ_1 and γ_2 , $F - \{\text{singular points}\}$ is no longer connected. In fact, we have introduced a new component (the one containing the trivial loop with monodromy (34) in figure 16 (f)) inside B_α . Nevertheless, the elimination process can be iterated, since all the remaining cusps are out of B_α .

3. Final remarks

First of all, we observe that, if M is a covering of S^4 branched over the image of a transversal immersion of a surface F in S^4 , then $\chi(M) = 8 - \chi(F)$, where χ denotes the Euler-Poincaré characteristic. It follows that F is not orientable if $\chi(M)$ is odd. So, we cannot require the orientability of the the branch surface in theorem B.

Anyway, theorem B could be improved by eliminating all the singularities of the branch surface (cf. [4]). This is not possible for orientable branch surfaces, but in the general case the following problem is still open.

Problem C. *Is every closed oriented PL 4-manifold a simple 4-fold covering of S^4 branched over a locally flat PL surface?*

Up to unoriented cobordism, the answer to this problem is yes, that is every cobordism class of 4-manifolds is cobordant to a simple 4-fold covering of S^4 branched over a locally flat PL surface. This can be proved by observing that, in the coverings given by theorem B, double points even occur in pairs (see figures 3–5, 16 and 17), and any pair of double points can be easily removed by using a piping technique, whitout changing the cobordism class of the covering manifold. This means that, we can limit ourselves to study problem C for bounding 4-manifolds.

References

- [1] I. Berstein and A.L. Edmonds, *The Degree and Branch Set of a Branched Covering*, Invent. math. **45** (1978), 213–220.
- [2] H.M. Hilden and R.D. Little, *Cobordism of branched covering spaces*, Pacific J. Math. **87** (1980), 335–345.
- [3] J.M. Montesinos, *A note on moves and irregular coverings of S^4* , Contemporary Mathematics **44** (1985), 345–349.
- [4] J.M. Montesinos, *4-manifolds, 3-fold covering spaces and ribbons*, Trans. Amer. Math. Soc. **245** (1978), 453–467.
- [5] J.M. Montesinos, *Heegaard diagrams for closed 4-manifolds*, in “Geometric Topology”, Academic Press 1979, 219–237.
- [6] R. Piergallini, *Covering moves*, Trans. Amer. Math. Soc. **325** (1991), 903–920.